



**MODEL DVR (ROUND) TYPE-B
GAS VENT INSTALLATION
INSTRUCTIONS**



Read through all of these instructions before beginning your installation. Failure to install as described in these instructions will void the manufacturer’s warranty and may have an effect on your homeowner’s insurance and UL listing status. Keep these instructions for future reference.

REFERENCES

- (1) National Fuel Gas Code, also referred to as NFPA 54 and ANSI Z223.1
- (2) Simpson Dura-Vent's Sizing Handbook, available from Simpson Dura-Vent

CONTENTS

REFERENCES 1

GENERAL INFORMATION 1

PLANNING 2

STEPS FOR TYPICAL INSTALLATION 4

BUCKET SUPPORT 9

COMBINATION TOP 10

ADJUSTABLE ELBOWS 11

MALE AND FEMALE ADAPTORS 12

RELINING MASONRY CHIMNEYS 13

MAINTENANCE 19

GENERAL INFORMATION

Type B Gas Vents are for venting listed Natural Gas or Liquid Propane Category I appliances only. The appliances listed below typically (but not always) use Type B vent systems.

- | | |
|----------------|---------------------------|
| Boilers | Furnaces |
| Water Heaters | Unit Heaters |
| Room Heaters | Duct Furnaces |
| Floor Furnaces | Decorative Gas Appliances |

Simpson Dura-Vent Type B Vent Systems may be used on other gas-burning appliances, provided the manufacturer of the appliance states in their installation instructions that Type B-vent is acceptable. **Donot** use Type B Vents for Category

II, III, or IV gas appliances. Type B Vent **shall not** be used to vent flue products from incinerators, combination gas/oil appliances, oil-fired, or wood-burning appliances. If there is a question about the use of Type B Vents, contact the appliance manufacturer or Simpson Dura-Vent's Engineering Department for further information.

PLANNING

1. **Appliances.** Carefully review the appliance manufacturer's installation instructions for positioning the unit, any special venting or connector requirements, and verify that it is a Category I appliance or an appliance that requires the use of Type B gas vent.

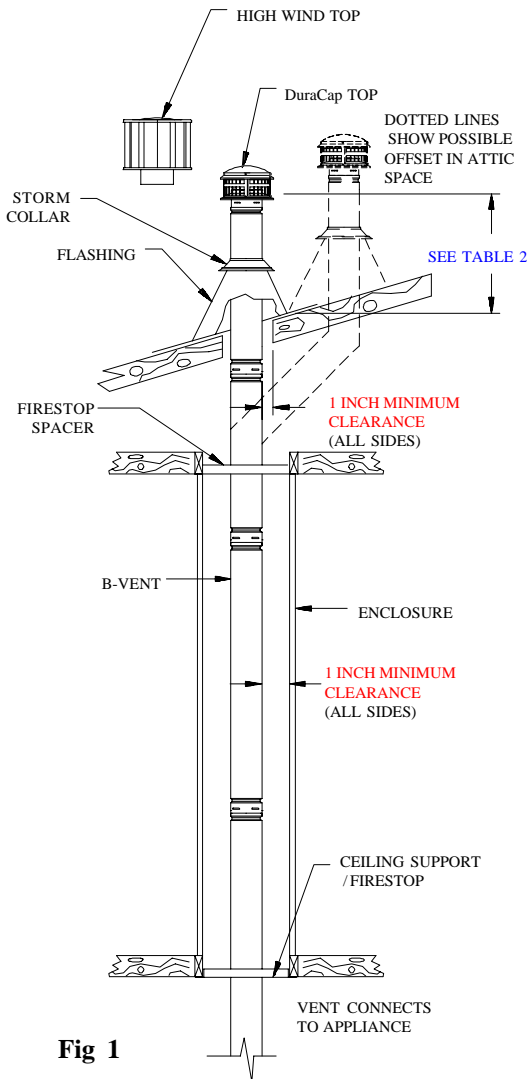

Fig 1

2. **Placement.** The placement of the vent and fittings must be in accordance with Local Codes, as well as accepted venting practices. If more than one appliance is to be connected to one venting system, the common vent must be correctly sized. It is a good idea to make a sketch of the proposed installation, labelling the components you will need. **Adjustable Pipe Lengths** are available to make up odd lengths. Minimize the number of turns and lateral runs, as the National Fuel Gas Code places limitations on these. A 45° turn is preferable to a 90° turn. The appliance reference material should be consulted at this time, as well as any Local Authority having jurisdiction. In most localities, building permits are required for any new appliances, or modifications to existing venting systems.

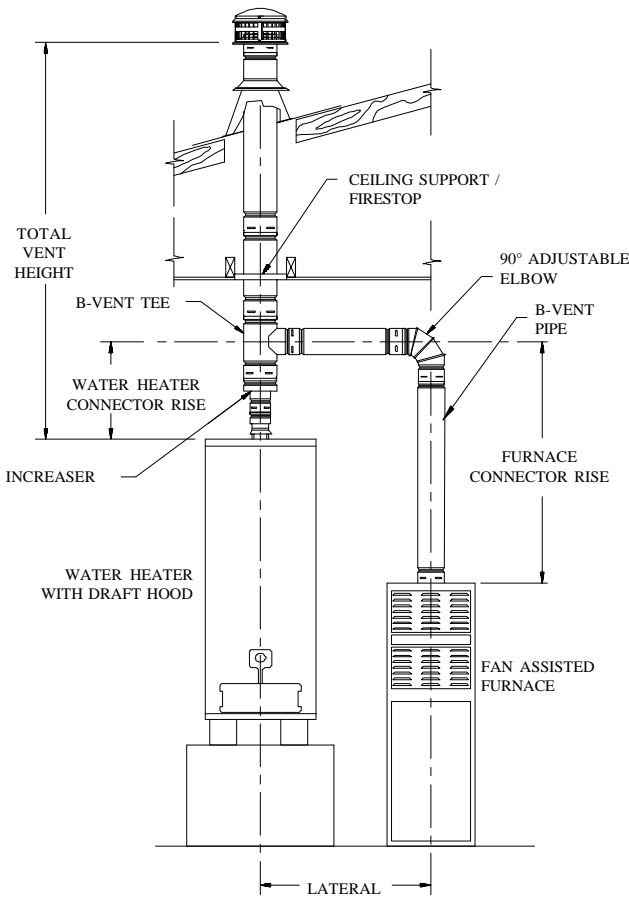

Fig 2

3. **Figures 1, 2, & 3** show examples of some typical residential installations.

4. **Clearance to Combustibles.** A **1-inch clearance (air space) to combustible materials must be maintained,** when using Simpson Dura-Vent Round B-Vent, regardless of the pipe diameter.

5. **Combustion Air.** Refer to appliance installation instructions and local building codes to ensure compliance with required volume of combustion air for each appliance installed .

6. **Slope.** If the venting system contains lateral (horizontal) components, they shall be positioned so they have an upwards slope away from the appliance of not less than 1/4-inch rise per foot of run. (Horizontal vent installed in attics, unconditioned area, or between floors have further restrictions, please consult your local building codes for specific limitations.)

7. **Termination Area.** Examine the area where the vent system will terminate. The height of the termination above the roof is determined by the roof pitch, and also it's proximity to adjacent walls or obstructions. Consult [Table 2](#) on [page 9](#) for proper termination height requirements. Vent pipe with 3"-12" diameter must terminate at least 2 feet higher than an adjacent wall or obstruction, if it

is within 8 feet. Vent pipe with 14" or larger diameter must terminate at least 2 feet higher than an adjacent wall or obstruction, if it is within 10 feet.

8. **Connector Rise.** Plan a minimum of one foot vertical connector rise coming out of each appliance.

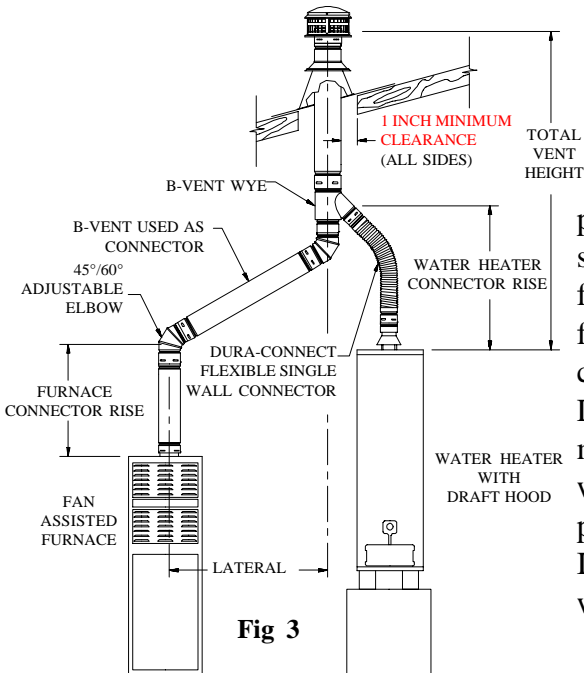

Fig 3

Dura-Connect installation procedures are contained in a separate instruction, obtainable from your Dura-Vent Dealer, or from Simpson Dura-Vent. The clearance to combustibles for Dura-Connect is one inch. It may not be used to pass through walls or ceilings, nor may it be placed in attics or crawl spaces. It may be used wherever single wall connector pipe is used.

STEPS FOR TYPICAL INSTALLATION

1. **Location.** Building Code requires the appliance(s) to be located as close to the vent as possible. After consulting the local codes, appliance installation instructions and any other applicable reference material determine the optimum location for the appliance(s).

2. **Penetration Point.** Locate and mark the center of the penetration point through the ceiling or the wall. Refer to Step 3 or 4, as appropriate.

3. **Ceiling Support.** For a ceiling supported system, install the **Square Firestop/Support** as shown in [Figures 6, 7, and 8](#). The **Firestop Support** must be framed in and the dimensions are shown in [Table 1](#) and shown in [Figure 4](#).

Table 1

PIPE SIZE	STOCK NUMBER OF CEILING SUPPORT	FRAMED INSIDE DIMENSIONS (X & Y) FIG 4
3 INCH	1440	7-3/8" X 7-3/8"
4 INCH	1441	7-3/8" X 7-3/8"
5 INCH	1442	9-1/8" X 9-1/8"
6 INCH	1443	9-1/8" X 9-1/8"
7 INCH	1444	11-1/8" X 11-1/8"
8 INCH	1445	11-1/8" X 11-1/8"
10 INCH	1446	13-1/8" X 13-1/8"
12 INCH	1447	13-1/8" X 13-1/8"

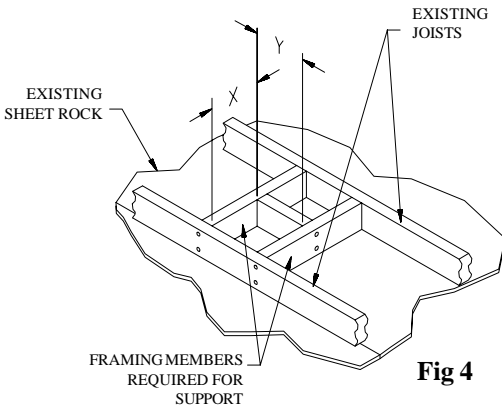

Fig 4

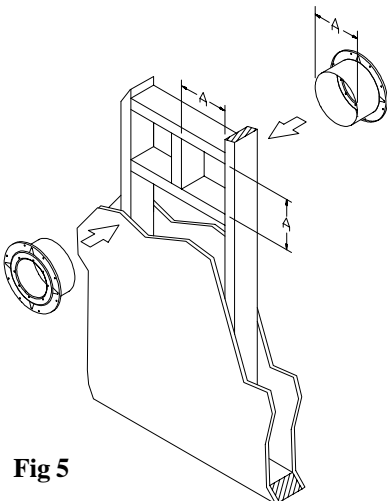

Fig 5

Firestop Supports are currently manufactured for pipe sizes of 3" through 12" only. Larger sizes may be locally fabricated from sheet metal, provided that the mandatory **1-inch clearance** is maintained, the pipe is adequately supported, and the installation is acceptable to Local Authorities. In

multistory buildings, a **Firestop/Spacer** must be provided at every floor /ceiling level other than the first floor which requires a support.

4. Wall Thimble. For a through-the-wall system, install the **Wall Thimble**, as shown in Figure 5. The **Wall Thimble** is designed to accommodate walls up to 6 inches thick. If you have thicker walls, a sleeve extension should be fabricated and attached to the existing sleeve. **Do not** fill the air space between the B-vent **Pipe Section** and the **Wall Thimble** with insulation, although an RTV-type sealant may be applied around the flange and nail heads if desired.

5. Pipe Assembly. Sections of Simpson Dura-Vent round pipe are joined together by lining up the female end of the locking lug with the male end slot, pushing them together, and turning clockwise to twist lock. Refer to **Figure 9**. Sheet metal screws are not needed for 3" through

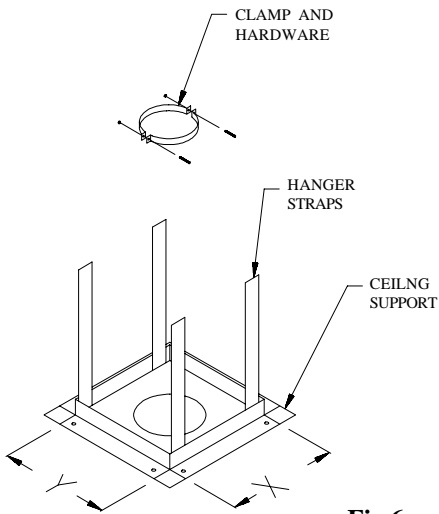

Fig 6

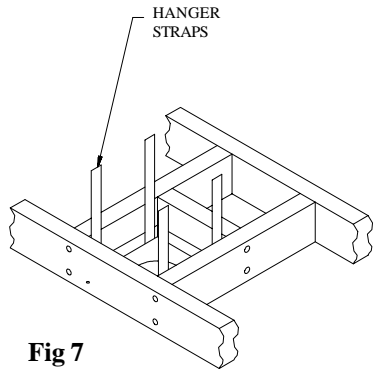

Fig 7

8" diameter pipe. However, if desired, use 1/4-inch long sheet metal screws for 3" through 8" diameter pipe. **Never** penetrate the inner liner with screws. For 10" through 16" diameter pipe, Simpson Dura-Vent recommends using a minimum of (4) 3/8" sheet metal screws per joint, and a minimum of (6) 3/8" sheet metal screws per joint for 18" and larger diameters. Each **Pipe Section** is labelled, and an arrow shows the direction of the exhaust flow. For ceiling supported installations, place a **Pipe Section**, or assembled **Pipe Sections**, through the hole in the **Square Firestop Support**, and tighten the **Clamp**. The **Clamp** will rest inside the **Ceiling Support**, and prevent the **Pipe Sections** from dropping down. The **Pipe Section(s)** should protrude a minimum of one inch below the ceiling. An optional **Pipe Collar** is available for decorative purposes.

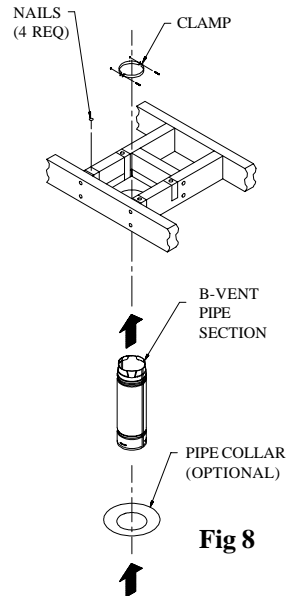

Fig 8

6. Connectors. Only Simpson Dura-Vent **connectors** should be used between the appliances and the venting system. Some appliances require **Type B-Vent** as a complete dedicated system from the flue collar of the appliance to the termination of the vent to the outside atmosphere. Simpson Dura-Vent's listed flexible, single-wall corrugated aluminum connector, called "**Dura-Connect**" can

be used in many applications when a B-Vent connector is not required.

7. **Elbows.** When **Elbows** are required, strap the **Pipe Sections** and/or **Elbows** in place using **Wall Straps**. Support the offset so that the weight of the offsetting pipe is not bearing down on the elbows, as shown in Figure 10.

8. **Tees and Wyes.** **Tees** and **Wyes** are used to combine connectors from 2 or more appliances into a common vent as shown in **Figures 2** and **3**. A **Tee** should be used in a through-the-wall application, (**Figure 11**), as they have a removable **Tee Cap** (available as a separate item) attached to the bottom. This **Tee Cap** may be removed in order to inspect the system, or to clean out debris or collected condensate from the common vent. **Wall Straps** should be positioned every four feet to support the vertical common vent.

9. **Enclosures.** Any portion of the vent which passes through an occupied area must be enclosed, to prevent accidental damage to the system, as well as

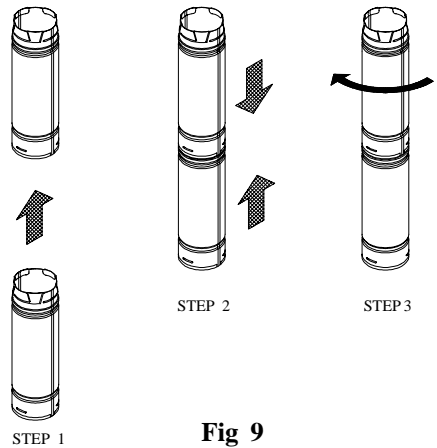

Fig 9

burns. **Figure 1** (page 2) shows a system which passes through an occupied second floor. Simpson Dura-Vent does not recommend installation of B-Vent Pipe on the outside wall of a building, particularly in cold climates. If it is necessary to do this, enclose the outside portion of the system in a chase, as shown in **Figure 11**. It would be wise to consult the Local Authority prior to construction. Note that the enclosure requires an access door for inspection and maintenance purposes.

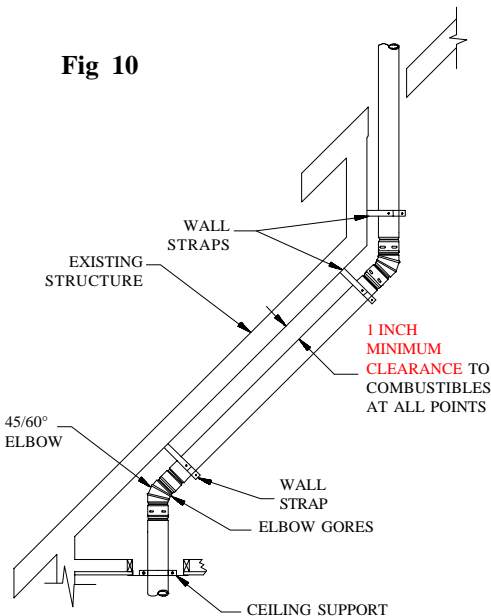

Fig 10

10. **Terminations.** Where the **Pipe Sections** pass through the roof, a hole must be cut to provide a **minimum**

clearance (air space) of 1 inch between the **Pipe** and construction materials. Straight lengths of **pipe** are run up above the roof. (see table 2) A **Roof Flashing** is placed down over the **pipe**, and adjusted so it fits tightly against the roof, with the **Pipe Section** held in a position maintaining the 1 inch minimum clearance from combustibles. The **Flashing** is then nailed to the roof. The roofing material (shingles, asphalt paper, etc.) should overlap the top edge (up-hill side) of the **Flashing**. A non-hardening sealant should be used around the edges of the flashing base where it meets the roof, as shown in Figure 12. Non-hardening sealant is placed around the joint between the **Flashing** and the vertical **Pipe Section** and the **Storm Collar** is then placed over this joint, to make a watertight seal. Add sufficient **Pipe Sections** to attain the height specified in Table 2. To connect the Top to the pipe, hold Top by its collar, slide collar over locking lugs of pipe, and twist-lock clockwise. **Tops** of diameters greater than 16 inches do not twist-lock, but are affixed with sheet metal screws.

11. **Inspection.** This com-

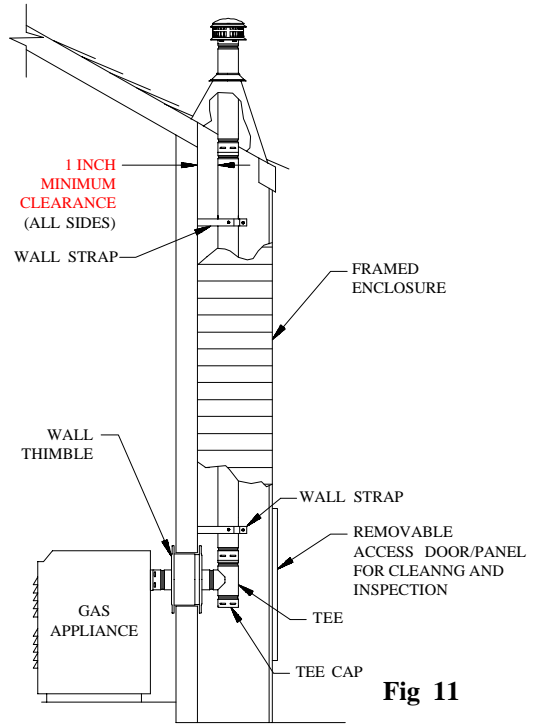

Fig 11

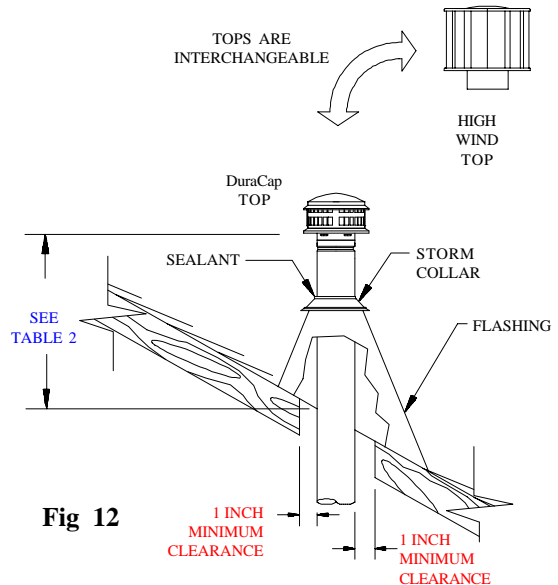

Fig 12

pletes the installation steps. Conduct a final inspection to insure that all joints are secure, the system is properly supported, and is mechanically sound. Especially verify that the **one-inch clearance to combustibles** requirement has been met, and that adequate combustion air will be furnished to the appliance.

GAS VENT SYSTEMS USING VENT CAPS LISTED BY UNDERWRITER'S LABORATORIES MAY TERMINATE IN ACCORDANCE WITH THIS VENT TERMINATION TABLE		
ROOF PITCH	MINIMUM HEIGHT	
	FEET	METERS
FLAT TO 7/12	1	0.3
OVER 7/12 TO 8/12	1.5	0.46
OVER 8/12 TO 9/12	2	0.61
OVER 9/12 TO 10/12	2.5	0.76
OVER 10/12 TO 11/12	3.25	0.99
OVER 11/12 TO 12/12	4	1.22
OVER 12/12 TO 14/12	5	1.52
OVER 14/12 TO 16/12	6	1.83
OVER 16/12 TO 18/12	7	2.13
OVER 18/12 TO 20/12	7.5	2.29
OVER 20/12 TO 21/12	8	2.44

BUCKET SUPPORT

1. Description. The **Bucket Support** (shown in Figure 13) is for properly supporting the B-vent between 16 or 24-inch O.C. joists or rafters, or for providing a transition fitting

between **Dura-Connect**

Single Wall Connector and the B-vent **Pipe Sections**. A maximum of 20 feet of Type B Gas Vent may be supported. Note that the **Bucket Support** must be installed prior to the sheetrock.

2. Assembly. After you have determined where the B-vent should be located, assemble the **Bucket Support** and **Brackets**. Nail the assembly to the bottom side of the joist material as shown in Figure 14. After the **Support Bucket** is in place, scribe and cut out a hole in the sheet rock 1/8" larger than the diameter of the **Bucket**, and

Table 2

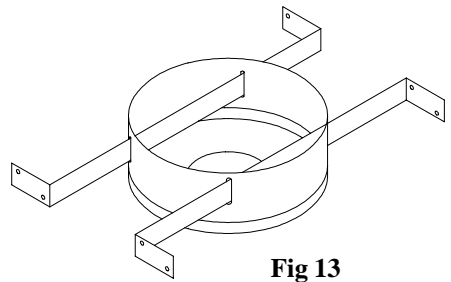

Fig 13

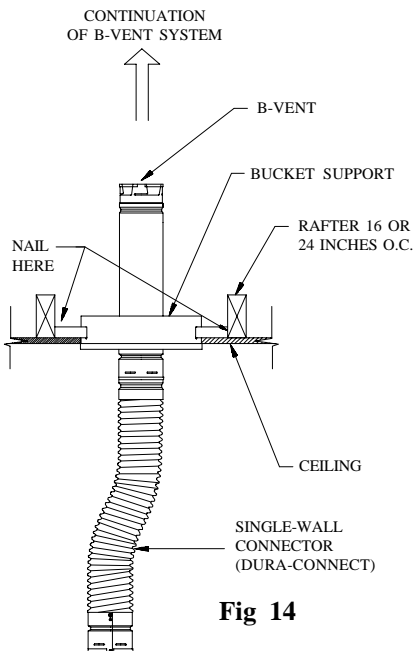

Fig 14

nail into place. Run the **Pipe Sections** through the hole in the **Bucket Support**, connect the **Dura-Connect Single Wall Connector**, and attach the **Clamp** so that it rests inside the **Bucket**, and will support the **Pipe**. Adjust the **Pipe** to the desired height and tighten the **Clamp**. This will provide a complete engineered support system.

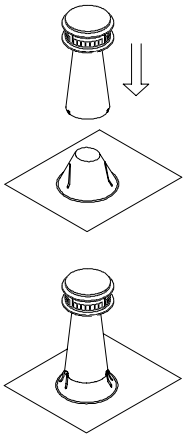

Fig 15

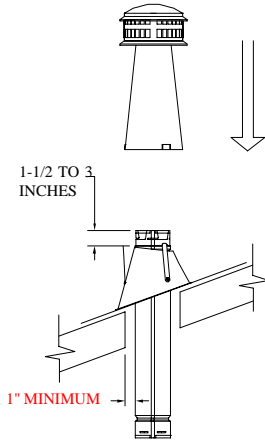

Fig 16

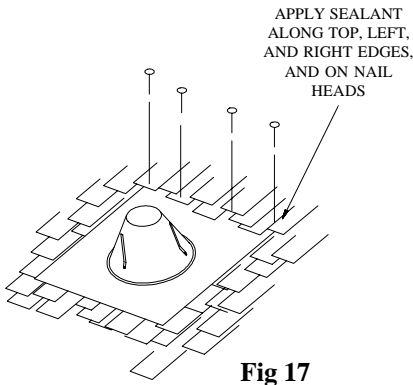

Fig 17

will allow a **minimum of 1 inch** air space between the B-Vent and combustible roofing materials.

4. **Flashing.** Position the **Flashing** so the hole is directly over the end of the pipe, as shown in Figure 16. Run the top edge of the **Flashing** under the roof covering, nail as required,

COMBINATION TOP

1. **Description.** The **Combination Top**, provides an easily installed, safe and efficient B-Vent **Top and Flashing**, as one lightweight unit. The two basic components and the assembled unit are shown in Figure 15. The **Combination Top** is designed to accommodate roof pitches from flat to 6/12, and is available for 3" through 6" diameter B-Vent pipe.

2. **Location.** Locate the point in the underside of the roof where the system is to penetrate, using a plumb bob or level.

3. **Hole.** Remove sufficient roofing material to cut a hole in the roof which

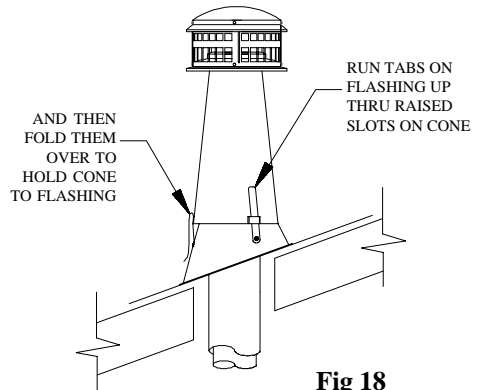

Fig 18

and seal with a non-hardening sealant, as shown in Figure 17. Seal all nail heads.

5. **Height.** Add sufficient **Pipe Sections** of B-Vent until the system terminates 1-1/2" to 3" above the collar of the **Flashing** as shown in Figure 16.

6. **Top Cone.** Slip the **Top Cone** over the **Flashing**, so the vertical straps on the **Flashing** coincide with the slots at the base of the **Cone**. Slip the straps up through the slots as shown in Figure 18. Adjust the **Top Cone** to a generally vertical position. Holding the **Top Cone** in position, bend the straps down as shown.

7. This completes the installation. Conduct a final inspection of the job to insure proper joints, correct procedures, sealed nail heads, etc.

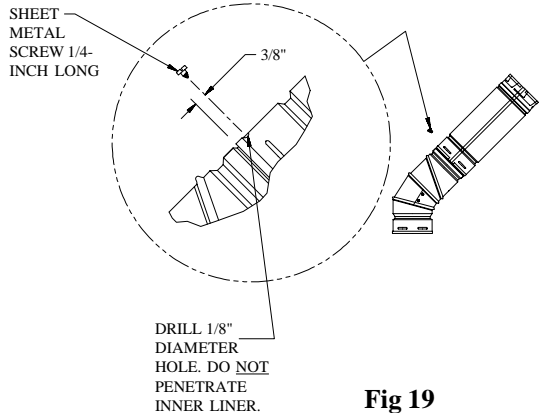

Fig 19

ADJUSTABLE ELBOWS

1. **Purpose.** This section furnishes supplemental information concerning **Adjustable Elbows**, both 90° and 45°/60°.

2. **Connections.** In addition to twist locking the elbows, the connection may be further secured by using sheet metal screws at the joint where the male and female parts overlap, provided that the screws **do not** penetrate the inner liner as shown in Figure 19. One screw per joint is normally sufficient. Use #8 Pan Head sheet metal screws which are no longer than 1/4 inch. Liberal use of **Wall Straps** for additional support is recommended. Do not allow the weight of the offsetting pipe to bear down on lower elbow.

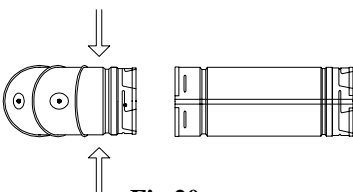
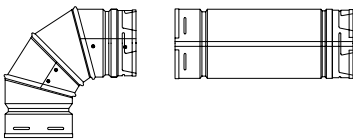

Fig 20

3. **90° Elbows.** Figure 20. The installer should apply pressure to the section at the points indicated by the arrows. This will prevent the adjacent sections of the elbow from turning, as the next pipe or fitting is twist-locked on. This is important, because once these sections start rotating, the elbow

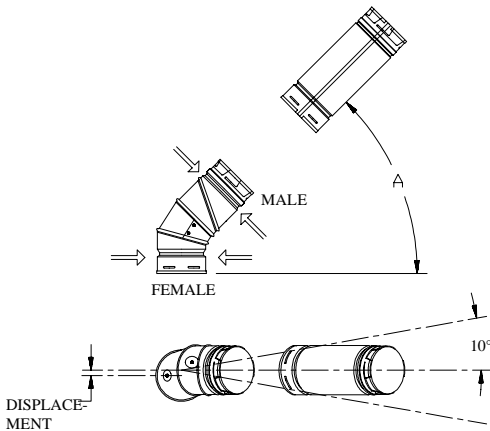

Fig 21

does no longer have a 90° angle.

4. 45° Offsets with 90° Elbows.

Figure 21 shows a **90° Adjustable Elbow** being utilized to accomplish a 45° offset. This **Elbow** is completely adjustable from 0° to 90°. Please note that the centers of the upper sections tend to displace by a slight amount, as they are rotated. Again, screws (not longer than 1/4") may be used to secure the joint. **Wall Straps** should also be utilized to enhance the stability of the vent system.

MALE AND FEMALE ADAPTORS

1. **Description.** The male and female adaptors enable an installer to connect Simpson Dura-Vent B-vent components to an existing Type B gas vent system manufactured by the following companies: American Metals Products, Household Mfg, Hart & Cooley Mfg, Metal Fab, Inc, White Metal Products, Air Jet, Mitchell Metal Products.

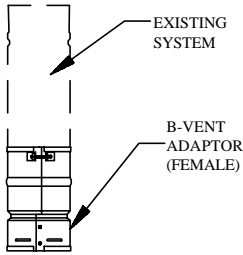

Fig 22

2. Connecting into Existing Competitors System.

To connect into an existing competitors gas venting system from below, or from the appliance side, connect a **Female Adaptor** as shown in Figure 22, insuring that the inner liner of the adaptor is outside the inner liner of the existing pipe. Push the adaptor as far up as it will go, and tighten the locking bolt until the connection is snug.

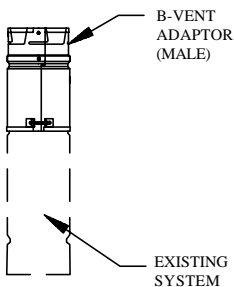

Fig 23

3. Extending an Existing Competitors System.

To continue an existing competitors system up towards the termination using Dura-Vent Type B Gas Vent, connect a **Male Adaptor** to the last section of the system, as shown in Figure 23, insuring that the inner liner of the

Adaptor fits smoothly inside the **Pipe** or fitting below it. Push the **Adaptor** down as far as it will go, and tighten the locking bolt until the connection is snug.

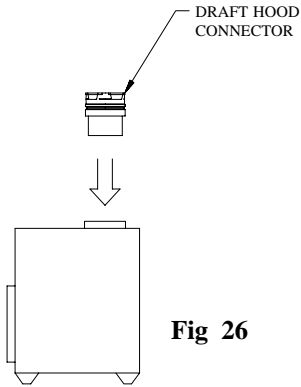

Fig 26

in your measurements.

(b) **Pipe and Fitting Requirements.**

The bottom 5 foot section of vent will be **Flex Pipe** (used to get around the smoke shelf, and to connect to the appliance). The remainder will be rigid **B-Vent Pipe Sections**. For each pipe

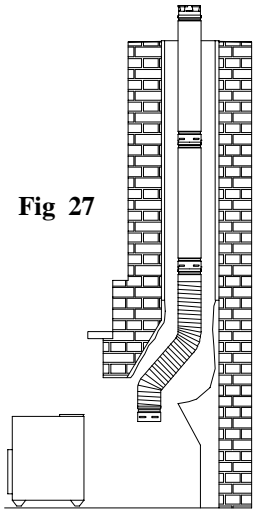

Fig 27

joint, subtract 1-1/2 inches.

(c) **Connector.** Read the appliance manufacturer's instructions for connecting the **Flex Pipe** to the appliance. In most cases, a **Draft Hood Connector** will be required as shown in Figure 26. If you are not sure, contact the appliance manufacturer for clarification. Place the appliance out in front of the fireplace area, as shown in Figure 27, and install the **Draft Hood Connector**, or other device in accordance

with the appliance instructions. The **Flex Pipe Coupling** may be able to attach directly to the appliance.

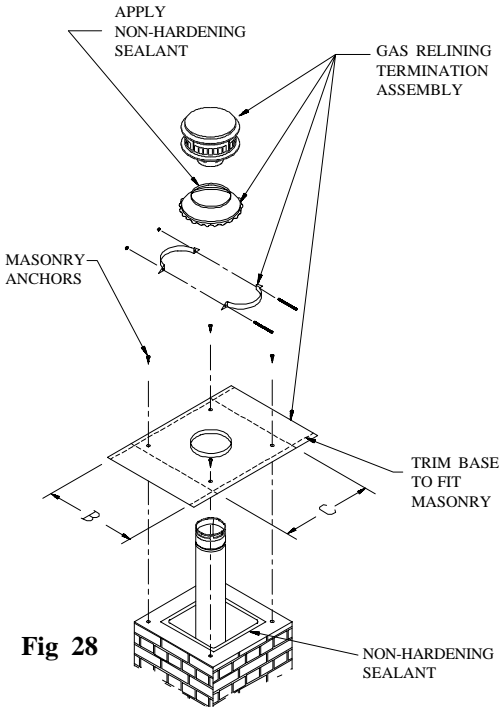

Fig 28

(d) **Flex Pipe Assembly.** Assemble first **Rigid Pipe Section** to the **Flex Pipe**, insuring that the "UP" arrows are in fact, pointing up. Push the sections together and twist to lock. Screws are not required, however if you desire to use them, use #8 sheet metal screws 1/4-inch long, being careful not to penetrate the inner liner. Repeat this process for the remainder of the **Pipe Sections**, and lower the assembly down the chimney. Lower it below its normal position as shown in Figure 28.

(e) **Position and Connect**

Fireplace. Push the gas fireplace towards the firebox, and connect the **Flex Pipe** female coupling to the appliance, or to the appropriate connector as specified by the appliance manufacturer. If insufficient space is available between the top of the appliance, and the fireplace opening, an access opening in the opposite side of the masonry chimney may be necessary. Position the gas appliance on it's final location, again complying with the manufacturer's instructions in regards to location. Install any shields or covers at this time.

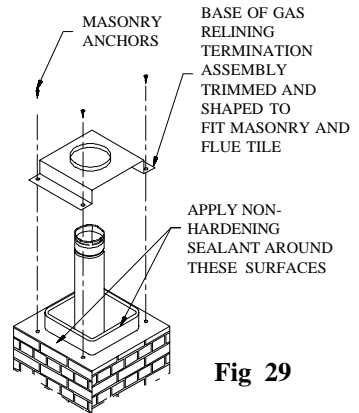

Fig 29

(f). **Adjust Height.** Go to the top of the chimney and pull the vent system up to its desired height. In most cases, this will be 12 inches above the masonry surface. Make a mark on the **Pipe Section** even with the top of the masonry surface. If the **top** of the pipe is near a steep roof (more than 7/12 pitch) ,use the height as stated in [Table 2](#).

(g). **Termination Assembly.** Trim the **Base Plate** of the **Termination Assembly** to cover the masonry opening. Refer to [Figures 28](#) and [29](#). Slip the **Base** down over the protruding **Pipe Section**. Use masonry anchors and non-hardening sealant to secure the **Base** to the masonry.

(h). **Clamp.** Pull the **Pipe** up through the **Base** to the mark, which you previously made. Slip the **Clamp** down to the mark, and tighten it securely to the **Pipe**. The **Clamp** will then support the entire venting system. Slip the **Storm Collar** down over the **Pipe Section**, and seal the joint with a non-hardening sealant.

(i). **Top.** Install the **Top**, as shown in [Figure 28](#). This concludes the procedures for installing a gas fireplace in an existing masonry fireplace. Conduct a final inspection of the system, and verify that the manufacturer's installation instructions have been totally complied with.

2. Gas Appliance Venting Into the Side Wall of a Masonry Chimney.

(a). **Locate Appliance.** Set the appliance in it's desired position, and mark the center of the hole where the lateral **Pipe Section** is to pierce the masonry chimney. Insure the manufacturer's requirements are complied with, particularly in regards to distances from combustibile surfaces. Refer to [Figure 30](#).

(b). **Hole in Masonry.** Move the appliance aside, and break out the masonry, forming a hole large enough for the **Pipe Section** to get through, and also

large enough to reach through and hold the **Tee**, while connecting the horizontal **Pipe Section**. An alternate procedure is to make the hole only large enough for the **Pipe Section** to pass through, and construct an access gate on the other side of the masonry chimney. **Do not mortar to the pipe.**

(c). **Tee.** A **Tee** is installed at the bottom end of the assembled vertical **Pipe Sections**, as shown in Figure 30. The **Tee** has a removable **Tee Cap** at the bottom, for cleaning and condensate removal. If the configuration of the building permits it, a clean-out access gate is recommended.

(d). **Vertical Pipe Sections.** Run the assembled vertical **Pipe Sections** (with the **Tee** attached to the bottom), down the chimney, until the horizontal branch of the **Tee** is opposite the hole in the masonry.

(e). **Adjust Height.** Hold the assembled **Pipe Sections** in this position, and make a mark even with the top surface of the masonry chimney. The vertical **Pipe Sections** should protrude 12 inches (in most cases) above this mark. If the top of the pipe will be near a steep roof (more than 7/12 pitch), use the height as stated in [Table 2](#).

(f). **Termination Assembly.** Trim the **Base Plate** of the **Termination Assembly** to cover the masonry opening. Refer to [Figures 28](#) and [29](#). Slip the **Base** down over the protruding **Pipe Section**. If necessary, use masonry anchors and non-hardening sealant to secure the **Base** to the masonry or bend base to secure.

(g). **Clamp.** Pull the **Pipe** up through the **Base** to the mark, which you made previously. Slip the **Clamp** down to the mark, and tighten it securely to the **Pipe**. The **Clamp** will then support the entire venting system. Slip the **Storm Collar** down over the **Pipe Section**, and seal the joint with a non-hardening high temperature RTV.

(h). **Horizontal Pipe Section(s).** Run the horizontal **Pipe Section(s)** through the hole in the masonry, and connect it firmly to the **Tee**, either by reaching through the hole, and holding the **Tee** while twisting the **Pipe Section**, or by holding the **Tee**

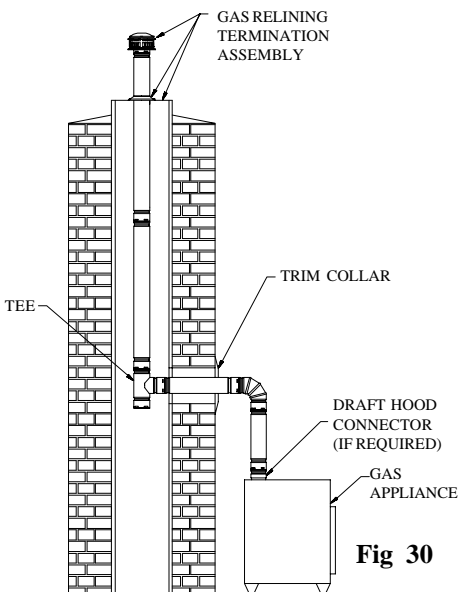

Fig 30

through the access door while someone twist-locks the **Pipe Section** to it. Use an **Adjustable Pipe Length** as needed to obtain a specific location for the appliance. Make a mark on the horizontal **Pipe Section** flush with the vertical face of the masonry, for referencing the vertical position. Slip a **Pipe Collar** over the horizontal **Pipe Section** and install the remaining fittings as shown in **Figure 30**. A minimum of 12 inches of connector rise is required.

(i). **Insulation.** Pull the **Pipe Collar** towards the **90° Elbow**. Fill in the gap between the masonry and the horizontal

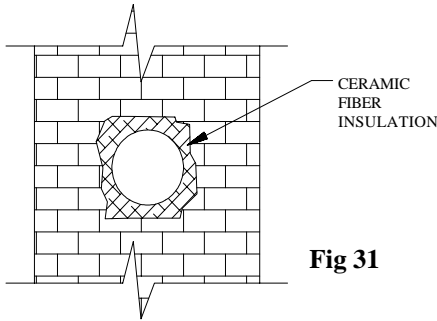

Fig 31

Pipe Section with ceramic fiber insulation or fiberglass, as shown in **Figure 31**. If fiberglass is used, remove any paper backing. The filling may be faced off with grout, if desired. Push the **Pipe Collar** back flush with the masonry. Make any final adjustments on the **Adjustable Length Pipe** (if used), and tighten the clamping bolts.

TROUBLESHOOTING

1. **Purpose.** This section is intended as a general maintenance and troubleshooting guide, and as such, cannot encompass all configurations or vent designs. For problems encountered which are beyond the scope of this sheet, contact your Dura-Vent Dealer, Distributor, or Simpson Dura-Vent's Engineering Department. **It is imperative that the one-inch clearance (air space) defined in these instructions be maintained.** In most cases, a **one-inch minimum clearance** must be maintained to combustibles. The only exceptions are 4-inch, 5-inch and 6-inch **Oval B-vent** which are installed within stud walls. **Oval B-vent** and **BW Vent** are the subject of a separate installation instruction, and are not discussed here. In these cases, the clearances are established by the listed **Firestop Spacers** described in the instructions for **Oval B-Vent**.

2. **Appliance.** Read the appliance installation instructions carefully, insuring that the prescribed clearances are met, and that it is a Category I appliance.

3. **Spillage.** Spillage from an appliance draft hood may cause condensation on windows, or odors that the occupant may notice. Spillage may be caused by an incorrectly sized vent system, blockage of the vent system, or a downdraft in the vent. Other causes are: excessive lateral runs, too many elbows, improper pitch to lateral runs (1/4 inch per foot of run is correct), fans or ventilation systems in the same general area as the gas appliance, or wind conditions at the

vent cap.

4. **Blockage.** Check the system for blockage by removing the cap, and looking down into the vent with a flashlight. Check for bird nests, debris, rodents, insects, or other obstructions. If nothing is found, inspect the entire system for physical damage.

5. **Downdraft.** Downdrafts are generally caused by the system's termination being too close to an adjacent wall, parapet, or other structure. If the cap is within eight feet of such an obstruction, it must also be at least two feet above it. Also insure that the top is at the height prescribed for your roof pitch in [Table 2](#). Inadequate combustion air is also a major cause of downdraft problems. Appliances like clothes dryers or other exhausting appliances in the same utility room can cause downdraft problems.

6. **Condensate/Corrosion.** Continuous condensate can cause corrosion (rusting) of vents, tops, appliance draft hoods, and other components of the system, as well as the inside of the appliance. **This situation can be extremely dangerous, and corrective action must be taken immediately.** Common causes of corrosion are listed below: If in doubt call a professional to inspect the vent.

(a) If the vent system is located in an area where spray cans or solvents are used extensively, (laundry areas, or paint shops, for example), the halogenated compounds get into the combustion air. When they are burned, they form compounds that cause corrosion. The corrective action in this case, is to isolate the appliance, and get the air supply from outside, or an uncontaminated area.

(b) Condensate may be caused by incorrect sizing of the vent system. Follow the procedures in the various sizing publications to obtain the correct sizes for connectors and vents. Other causes are: excessive lateral runs, too many elbows, cold attics and crawl spaces, and large areas of the exterior portions of the venting system exposed to cold weather. As a general rule, laterals should be held to a minimum, and be no longer than 75% of the vertical height of the system. Condensate may initially appear as beads on the outside of the connector or vent.

7. **Construction.** Laterals, offsets, and vertical components should be securely supported with wall straps, as previously described. Components of the vent which are in occupied areas should be enclosed to prevent accidental contact and damage to the vent system. Insure that insulation, building materials, or debris do not extend into the required clearance spaces. In cold climates, the exterior portions of the vent should be enclosed in a chase. Outside portions of the vent system with may be painted with high temperature paint to help

prevent rusting and corrosion on the exterior surfaces.

MAINTENANCE

1. An annual inspection is required to maintain warranty of your Simpson Dura-Vent B-Vent system. You will need to inspect the **Cap, Vent Pipe, Connector Pipe**, and the connection to the appliance.
2. Verify that the sealant around the Flashing and Storm Collar is intact. Reseal as needed. Remove Cap. Hold Cap by the collar only, and unlock by twisting counterclockwise, and then pull up. Grabbing the Cap by the outer edge or top can cause damage to the Cap.
3. Inspect Cap for any physical damage or damage from corrosion. Look for any foreign material inside the cap or vent. (Example: bird's nest, leaves, etc.)
4. Shine a light down inside of the vent pipe. Look for any evidence of damage, corrosion or excessive condensation. Also, look for any disconnected sections of the vent pipe or connector pipe. Refer to the installation instructions to reconnect pipe sections. If pipe sections are damaged or corroded, **replace immediately!**
5. Replace Cap by grabbing cap (by collar only), and slide onto pipe section and twist-locking (clockwise).
6. Inspect appliance connector and make sure that the vent is securely connected to the appliance.
7. Damaged or corroded parts should be replaced immediately! Failure to do so can lead to an extremely hazardous situation!
8. Follow your appliance manufacturer's recommended instructions for inspection your appliance.

Simpson Dura-Vent offers the industry's only twenty-five year warranty on Type B gas vent system and is UL listed. This warranty is in effect from the date of installation and includes all components and fittings. Simpson Dura-Vent warrants the following products: All Fuel Class A Chimney - Dura/Plus® and Dura-Chimney®; Close Clearance Connector Pipe - DVL®; Type B Gas Vent and Pellet Vent® Chimney for a period of twenty-five years from date of installation. Warranty includes all component fittings, except rain caps, which is covered for five years from date of installation. Direct Vent GS® is warranted for ten years from the date of installation. Dura/Connect® is UL listed, approved by ICBO, BOCA and SBCCI and is warranted for ten years from the date of installation. DuraFlex® pipe and fittings is UL and ULC listed and is warranted for ten years from the date of installation. Warranty includes component fittings, except cap assembly which is covered for five years from date of installation. Dura-Black® drip free stovepipe is warranted for five years from the date of installation. Dura/Liner® is UL and ULC listed and is warranted for twenty-five years from the date of installation. All warranties, whether expressed or implied, shall be limited to replacement (exclusive of installation costs) of our product found to be defective under its warranty and shall be conditional upon compliance with the manufacturer's recommended installation and maintenance procedures and intended use of the product, and providing all recommended installation and maintenance instructions are followed. All products must be maintained by periodic inspection and cleaning as needed, including chimney exposed to weather containing corrosive elements or contaminated intake air, due to storage of corrosive agents near the appliance. Always refer to warranty specifics for each product line.

SIMPSON Dura-Vent Co., Inc. All Rights Reserved, 1998



**SIMPSON
DURA-VENT, INC**

PO Box 1510
Vacaville, CA
95688-1510

(800)-835-4429
(707)-446-4740 (FAX)

Vicksburg, MS

November 1998
L204A